

Spiral Conveyors from Nercon

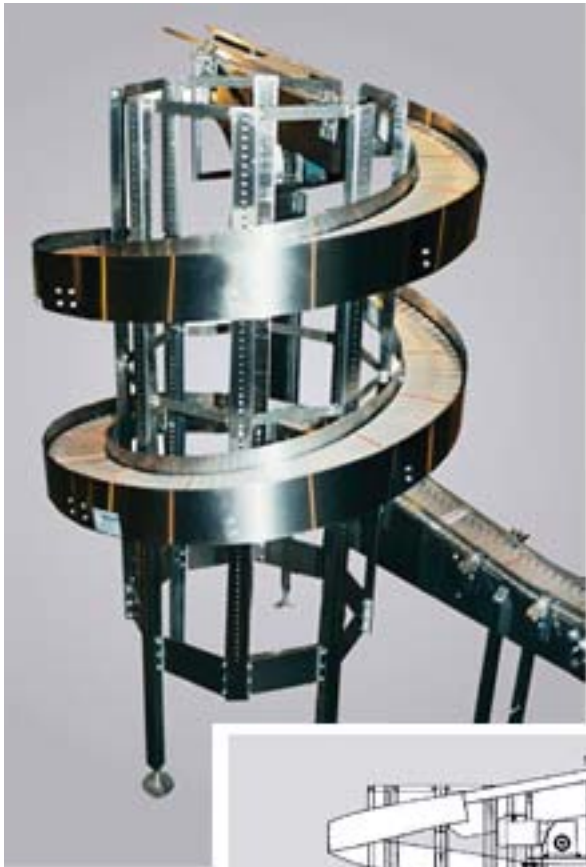

Nercon's Spiral Conveyor is compact in design compared to other vertical lift equipment and conveyor solutions. The Spiral Conveyor can be designed to carry product between floors and machines or over aisles.

Designed with a uniform slope, the Spiral Conveyor insures smooth operation without disturbing the product. A continuously moving table top chain gently elevates or lowers the product.

The Spiral Conveyor is suited for fragile products that cannot be squeezed with a gripper conveyor or if the product cannot be tilted.

Operating speeds up to 150 feet per minute are attainable depending upon the height change and product size and weight.

The Spiral Conveyor is adaptable to customer requirements. Multiple lanes, slope and chain widths are available ranging from 3 1/4" to 15" (double 1/2"). The infeed and discharge location is also variable depending on the application.

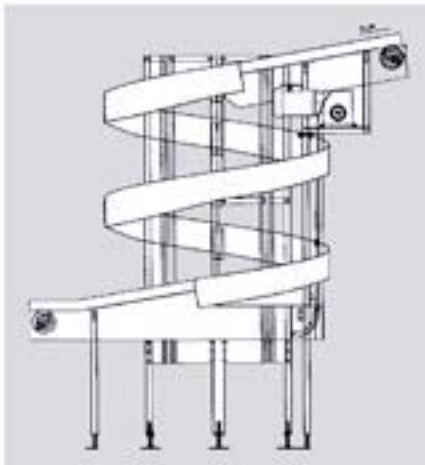

Left: With a minimum elevation of 20", the maximum elevation of Nercon's Spiral Conveyor is determined by conveyor speed and product weight.

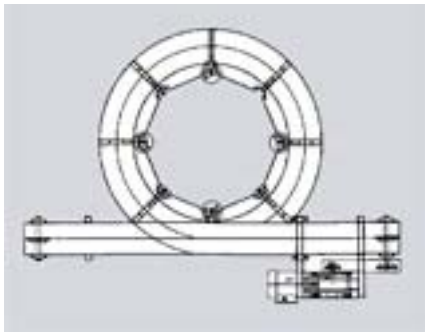

Left: Space saving Spiral Conveyor has a footprint of either 48" or 60" (center line) and a total width of either 107" or 119" (center line) from in-feed to exit point.